



The edges of some Green-vent components are sharp. Wear safety gloves to avoid injury when handling. All work carried out by the installer should be in accordance with the local laws & safety regulations.

Bypassing the Thermostat

For units without ECS

Turn the Green-vent upside down. Cut the cable ties holding the wires & thermostat (**fig.1**) to the bracket. Remove the black wires from the thermostat and the motor, and connect the longer wire coming from the Solar Panel directly to the motor. Using the 2 x cable ties supplied, fasten the wires back to the bracket.

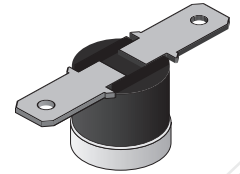

fig.1

Mounting the Fan

The solar fan should be positioned to face north for optimum performance and should be positioned on an area of the roof that is not shaded or otherwise blocked from the sun for extended periods throughout the day (**fig.2a**). If any circumstance where shade is unavoidable, a terminal cable for extension is provided so you can unmount the solar panel from the dome and place it to an optimal location (**fig.2b**). Terminal cable for extension is available on 30W units only.

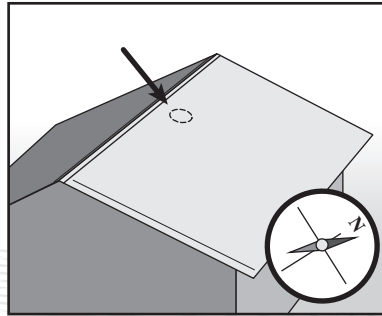

fig.2a

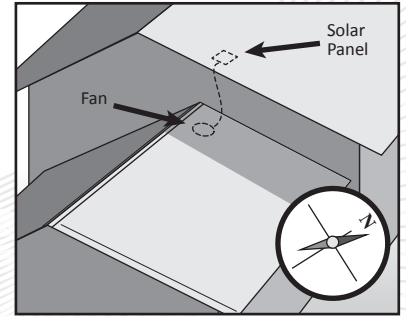

fig.2b

For Tile Roof

Decide where you will install the Green-vent Solar, a couple of rows down from the ridge is recommended. Remove approx 6 - 8 tiles. Cut and remove a portion of tile batten so that there is approx 320mm clearance, allowing unobstructed airflow to the Green-vent (**fig.3**).

The top of tray is installed under the top tiles whilst the lower end lays on the top of the tiles below (**fig.4**). Replace the side tiles, cutting if, or where necessary. To finish, mould the corrugated flashing into the profile of the bottom tiles (**fig.5**).

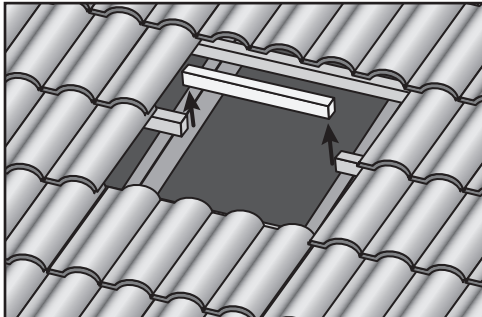

fig.3

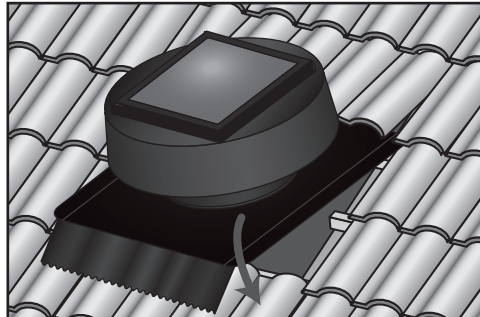

fig.4

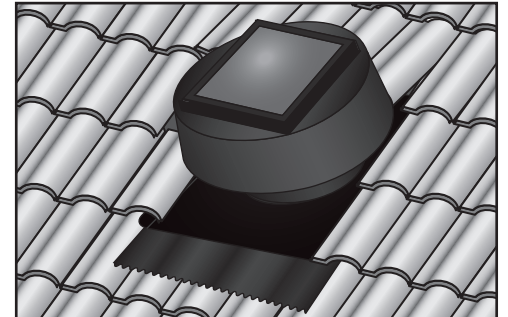

fig.5

For Custom Orb Roof

For optimum performance and weatherproofing, the Green-vent Solar should be installed along the ridge line of the building. Cut a hole where the GVS is to be installed using nibblers or snips, we do not recommend using an angle grinder. The hole should start and finish on the high points of a corrugation, which should equate to approx a 380mm width, which will give you one full corrugation either side of the hole covered by the flashing of the GVS. Cut the hole approx 380mm long, and approx 75mm from the bottom of the ridge flashing, this will allow the flashing of the GVS to be overlapped by approx 100mm. (**fig. 6**). Fold up the low points on the corrugations of the hole (**fig. 7**). Remove fixings from the ridge flashing, then insert the GVS flashing under the ridge flashing, put silicone between the two flashings, and re-install the fixings. Install fixings on the low side of the GVS flashing, into the high points on the corrugations of the roof (**fig. 8**). Using a hammer, and rag to protect the surface gently tap the front of the base flashing between the high points on the roof sheeting to mould the base flashing to the roof profile (**fig.9**).

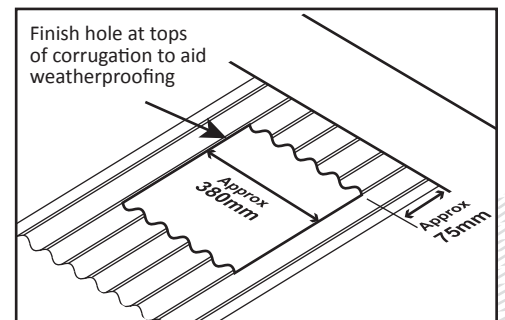

fig.6

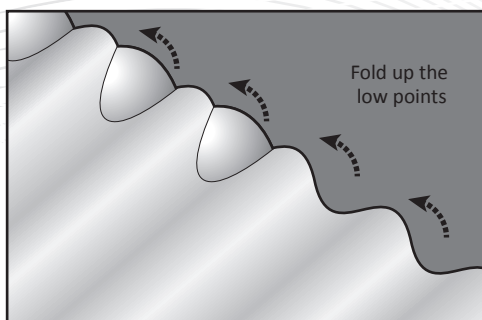

fig.7

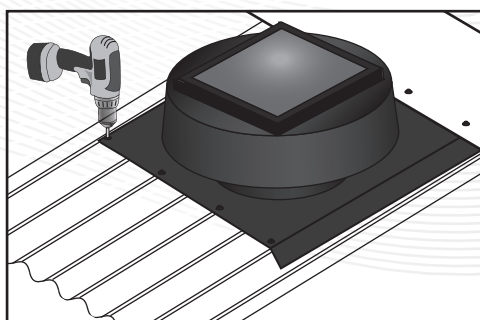

fig.8

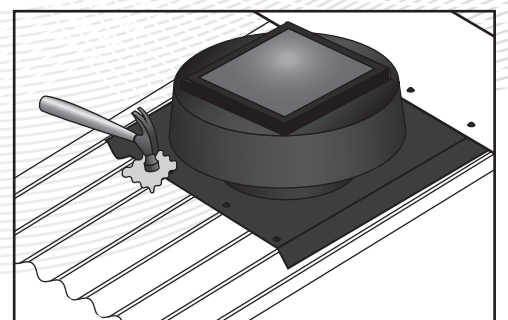

fig.9

Adjusting The Solar Panel Angle

For peak performance the Panel should always be angled to point at the midday sun (*fig.10*). This may involve the panel needing to be tilted and/or rotated (*fig.11*). Use your compass to find north, and the panel should be pointed as close as possible to this direction.

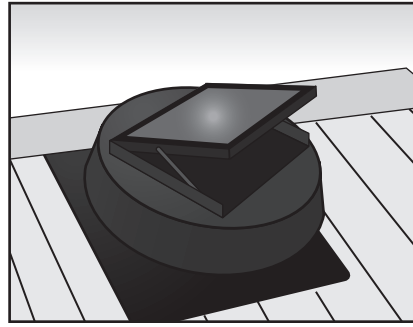

fig.10

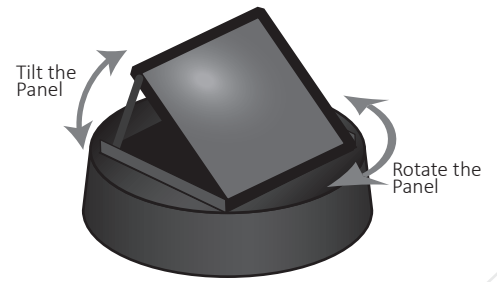

fig.11

Tilt the Panel

Undo the 2 x Self Drilling Waferhead Screws holding the panel to the plate. These are located on opposite sides of the panel, both of them are next to a rivet holding the tilt bracket to the plate (*fig.12*). Lift the panel to one of the 3 positions, and using the screws you removed, place the screw through the tilt bracket and screw back into the panel (*fig.13*).

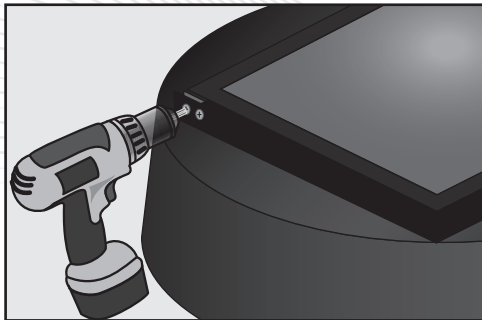

fig.12

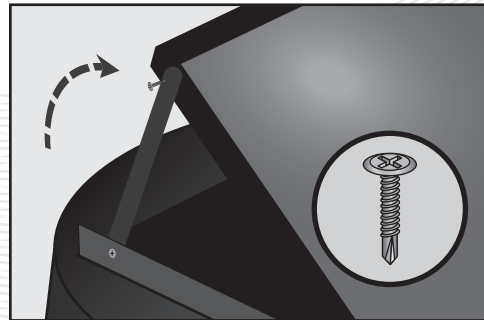

fig.13

Rotate the Panel

Undo the 2 x Self Drilling Waferhead Screws holding the panel to the plate. With the panel tilted out of the way, you can undo the 4 x Lock Nuts holding the plate to shroud. Place the nuts and washers safely to the side (*fig.14*). Lift the plate and rotate to the desired position (*fig.15*). Put the washers and lock nuts back on the bolts and tighten. You can now finalise the tilting of the panel if required, or just replace the 2 x Self drilling Waferhead Screws back into their original position and tighten (*fig.16*).

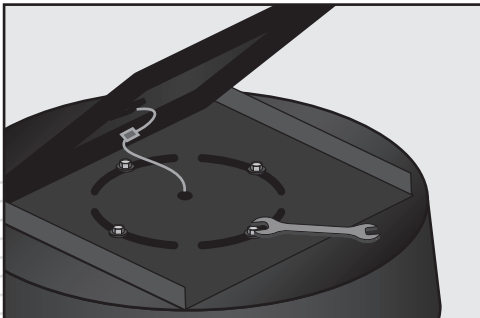

fig.14

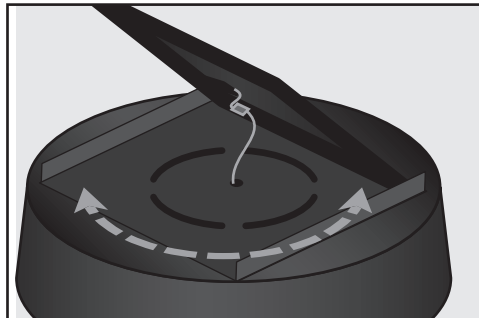

fig.15

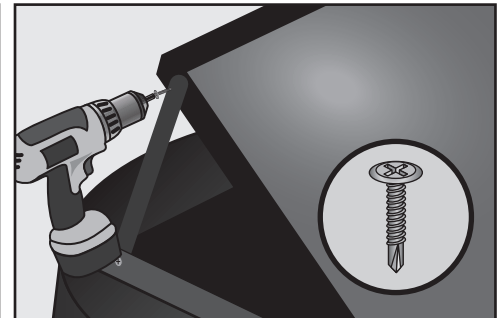

fig.16

The installed Green-vent Solar will look like on the picture when finished (*fig. 17*).

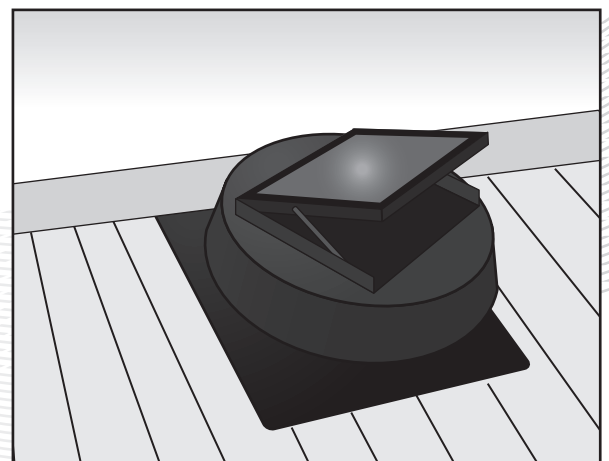

fig.17